

# Model MD1000-190 Specifications\*

(PRELIMINARY)

<b>Cathode Ray Tube</b>	5-Inch Measured Diagonally (127 mm)
	<b>Display Size:</b> 3.80 in. X 2.54 in.
	<b>Video Ampl. Voltage Gain:</b> 10 min. with a 2.5V P-P min.
	<b>Deflection Angle:</b> 55°
<b>Video Performance</b>	<b>Resolution:</b> 650 lines, center; 500 lines, corner
	<b>Bandwidth:</b> Within 3dB, 10Hz to 12MHz
<b>Synchronization</b>	<b>Horizontal:</b> 15.75 kHz ( $\pm$ 500 Hz)
	<b>Vertical:</b> 50/60Hz
	<b>Horizontal Blanking:</b> 11 $\mu$ Sec min. (time includes retrace and delay)
	<b>Vertical Blanking:</b> 900 $\mu$ Sec min. (time includes retrace and video display)
<b>Input Signal</b>	<b>Vertical Sync Drive:</b> 50 $\mu$ Sec. to 1.4 mSec. input, TTL compatible, negative (positive optional) pulse; 4.0V P-P $\pm$ 1.0
	<b>Horizontal Sync Drive:</b> 4 to 40 $\mu$ Sec input. TTL compatible, positive (negative optional) pulse 4.0V P-P $\pm$ 1.0
	<b>Video:</b> positive white, input impedance greater than 1k ohm
<b>Power Requirement</b>	<b>Operating Range:</b> +12 VDC ( $\pm$ 0.5V)
<b>Controls</b>	<b>Internal:</b> brightness, vertical size, vertical linearity, horizontal size, raster centering, vertical hold, contrast, and focus.
	<b>Optional:</b> customer supplied brightness control for operator adjustment
<b>Linearity</b>	<b>Character Size:</b> 1. Height and width will not vary more than 10% from the average character size. 2. Adjacent characters will not vary more than 10%.
<b>Operating Environment</b>	<b>Operating Temperature:</b> 0°C to +55°C
	<b>Storage Temperature:</b> -40°C to +65°C
	<b>Operating Altitude:</b> 10,000 ft. max.

## NOTE

CRT's with bonded etched panels should not be subjected to storage or operating temperatures above 50°C

## PERFORMANCE STANDARD:

THIS EQUIPMENT IS DESIGNED TO COMPLY WITH DHHS X-RADIATION PERFORMANCE STANDARDS, U.L. AND C.S.A. SPECIFICATIONS PROVIDING B+ TO THE MONITOR DOES NOT EXCEED 14VDC.

\* IN A CONTINUAL EFFORT TO UPGRADE OUR STANDARD PRODUCT AS NEW TECHNOLOGICAL ADVANCES ARE MADE. SPECIFICATIONS ARE SUBJECT TO CHANGE WITHOUT NOTICE.

## SERVICE NOTES

### GENERAL SERVICING PRECAUTIONS

#### — CAUTION —

Before attempting to service the monitor, disconnect (or turn off) the external power supply; then, as an added precaution, discharge the CRT 2nd anode before handling any high voltage components. In addition, be sure to observe all safety warnings and service notes in the front of this manual.

When it is necessary to disconnect the deflection yoke, and/or CRT socket leads, pull their small female pins straight out without any back and forth rocking motion. This will prevent, or at least minimize deforming male pins and/or breaking their solder connections.

Use caution around the heat sink of the horizontal output transistor. The heat sink is at the same potential as the transistor collector. During normal operation with signal input present, the horizontal heat sink has 165 volt P-P pulses (with respect to system ground).

### GENERAL SUBSTITUTION OF PARTS

When components need be replaced, order Motorola replacement parts only. Avoid using other substitute semiconductor devices as these can cause system performance degradation. In the event of failure, and the need for emergency system restoration, generic substitution of semiconductor devices used are provided as an aid on the Schematic Diagram and Parts List.

### COMPONENT REMOVAL

Due to the nature of solid state devices such as integrated circuits (IC's), and etched printed circuit cards, special desoldering tools and IC removing techniques should be used. Care should be exercised not to damage the printed circuit card, break or lift the copper foil, and create cold solder connections.

Integrated circuits are very reliable components and should not be replaced until all checks have proven definitely that the IC is the defective component. Removal of the IC is time consuming and often careless or sloppy soldering techniques can cause additional problems.

### CIRCUIT TRACING

For ease in troubleshooting, circuit card components are mounted on one side, with foil circuitry on the reverse side of the circuit card. Schematic reference symbols and numbers are screened on both sides of the circuit card to help

locate and identify circuit components during troubleshooting.

Familiarize and study the attached Schematic Diagram and hints provided in this Service Manual before attempting to bypass logical troubleshooting sequence of measurements. The Schematic Diagram in this Service Manual contains voltage readings and oscilloscope test patterns at key points of the electrical circuit. These readings are typical for normal operating conditions and should be considered nominal varying slightly from unit to unit. Any considerable variations should be investigated as a possible defective circuit point.

### ROUTINE PERIODIC MAINTENANCE

Routine periodic maintenance service should be performed on the Display Monitors as well as all supporting system equipment to avoid equipment down-time, and make necessary level adjustments to compensate for slow degradation in quality of display due to component changes, which if left unattended could result in costly and extensive repairs.

### ROUTINE PERIODIC INSPECTION

Routine inspection schedules will depend upon the surrounding environment where the system is installed and should include

- Check all controls for proper mechanical and electrical operation.
- Dust and clean optical surfaces. High quality display requires clean viewing surfaces.
- Examine all components for outward signs of damage.
- Repair loose or worn out electrical connections burned or discolored insulation and parts.

### LOCALIZATION OF TROUBLES

Localization of trouble is most frequently accomplished by performing the adjustment procedure as outlined in this Service Manual and noting the results or indications for comparison with normal operating conditions. Refer to the text portion of this manual on alignment procedures and the respective schematic circuit for additional information.

- Visually check for obvious physical defects or broken leads, broken plating, broken or disconnected (unsoldered) components, or overheating parts. If any attempt is made to change a component, the circuit should be checked to insure that the problem causing the original failure has been identified and corrected, otherwise damage to the new part may occur.

- Check voltages for proper levels at the suspected component and proper voltages at the surrounding circuits. Certain defects or broken plating, broken leads, etc., may not be obvious to a visual inspection.
- The isolation of trouble to a defective component is most easily accomplished with the use of a multimeter and observing normal transistor and IC servicing techniques. During the process of isolation, continuous references must be made to the appropriate section of the schematic diagram to determine circuit configuration.

## CRT REPLACEMENT

Use extreme care in handling the CRT as rough handling may cause it to implode due to high vacuum pressure. Do not nick or scratch glass or subject it to any undue pressure in removal or installation. Use goggles and heavy gloves for protection. In addition, be sure to disconnect the monitor from all external voltage sources.

### — NOTE —

Discharge the CRT by shorting 2nd anode to the aquadag; then remove the CRT socket, deflection yoke and 2nd anode lead.

### Procedure:

- Step 1. Remove the CRT socket, and the 2nd anode lead.
- Step 2. Remove push-in connectors (4) from both sides of the deflection yoke.
- Step 3. Remove (1) ¼-in hex head screw securing the printed circuit card to the chassis.
- Step 4. Gently slide the printed circuit card out towards the rear of the monitor. Do not use force as the printed circuit card is secured in place in nylon guiding rails. These guide rails are mounted to the sides of the chassis. When re-inserting the printed circuit card back into position, care should be exercised to first orient the card properly and making sure to align its sides into the nylon guide rails.
- Step 5. Loosen the screw on the deflection yoke and remove yoke.

### — NOTE —

The deflection yoke is secured to the neck of the CRT with hot melt adhesive. Carefully break the adhesive bond before sliding yoke from its position.

- Step 6. Remove the grounding spring clipped to the sides of the chassis.
- Step 7. Gently grasp the CRT from the rear and remove the (4) hex head screws securing the upper and lower CRT holding bracket. Slide the CRT out from the front.
- Step 8. Loosen the copper wire bracket holding screw and slide the bracket assembly off from the CRT.
- Step 9. Use Motorola Part No. 11-00131474 adhesive cloth tape to tape the sides of the replacement CRT before installing the CRT mounting brackets.
- Step 10. Reverse the procedure/steps to install the new CRT.

## OPERATIONAL CHECK/ADJUSTMENT PROCEDURES

### GENERAL

The following procedures are provided to check the operation of the monitor and perform simple preinstallation adjustments (if required), or readjust after servicing and component replacement.

When reference is made to adjust to a specific size display (vertically and horizontally), refer to original model specifications for correct dimensions by the monitor model number. This also applies to minimum and maximum tolerances when adjusting for correct CRT geometry, linearity, focus, etc.

### — NOTE —

To assist in understanding more of the preceding terminology, refer to a separate Motorola Manual, "Incoming Inspection Guide" (Motorola part number 68P25253A71).

Perform the procedures in the sequence presented, and allow at least five (5) minutes warm-up before adjusting the monitor. In addition, when instructed to disconnect an input signal, do not ground the signal at the circuit card edge connector (P1). This action could damage the signal source generator. Instead, disconnect the signal at its source.

CCW = Counter Clockwise Rotation, CW = Clockwise Rotation. (As viewed from rear of circuit card.)

### EQUIPMENT REQUIRED

- Regulated 12VDC Power Supply
- Precision Digital Voltmeter
- Non-Metallic Alignment Tool

Test Signals (Bench test signals must be same amplitude, polarity, and frequency as final installed operating signal source. Refer to original specifications for values by monitor model number.)

The following Motorola gauges are required for performing complete and accurate CRT geometry and linearity alignment. Refer to original model specifications for correct gauges to use.

Linearity Gauge      Slot Gauge      Parallelogram Gauge

## SERVICE ADJUSTMENTS

Use a non-metallic tool when performing the following adjustments.

### BRIGHTNESS/CONTRAST ADJUSTMENT

#### Procedure:

Step 1. Disconnect the Video Drive signal, input at pin 8 of edge connector P1.

—or—

If unit is equipped with a customer supplied Contrast control, rotate for minimum signal.

Step 2. Rotate internal Brightness control, R108, to minimum.

Step 3. If unit is equipped with a customer supplied Remote Brightness control, rotate to full maximum position.

Step 4. Rotate R108 to the threshold of the raster.

Step 5. Reconnect Video Drive signal. Adjust customer supplied Contrast control for a desired video level.

Step 6. Adjust the Remote Brightness for the desired brightness level.

### VERTICAL SIZE/LINEARITY ADJUSTMENT

#### Procedure:

Step 1. Connect a test generator whose output is identical to the signal normally used.

Step 2. Rotate the Vert. Size control, R208, until optimum size display is obtained.

Step 3. (Refer to Figure 1.) Adjust the Vert. Linearity control, R211, until extreme top and bottom characters (designated "A" and "B") are equal in height to the center characters (designated "C").

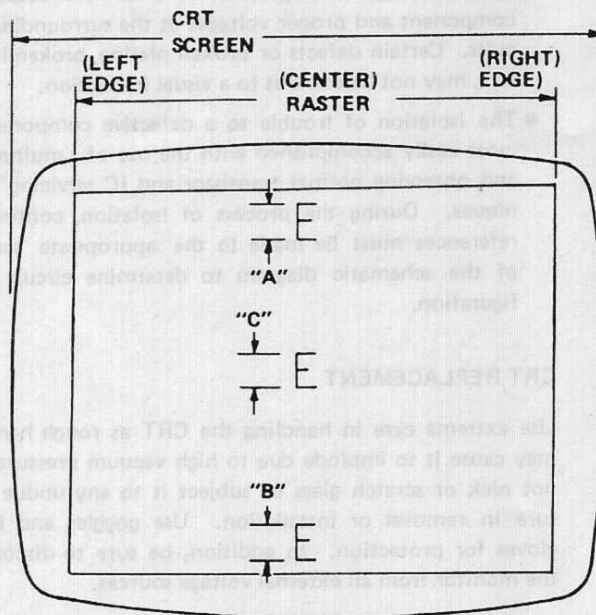

AEPC-01050-0

Figure 1. Partial CRT Display of Characters for Vertical Linearity Adjustment

Step 4. Readjust R208 until the desired height is obtained.

### FOCUS ADJUSTMENT

#### Procedure:

The optimum focus of the display is obtained by adjusting the focus control, R315, for best focus at a point that is near the center and approximately 1/3 down from the top of the display.

### RASTER CENTERING ADJUSTMENT

#### General

The deflection yoke of these direct drive monitors do not contain magnets; therefore, only raster centering is required whenever the CRT needs to be replaced.

#### Procedure:

Step 1. Adjust Vertical Size Control, R208, so that all edges of the raster are visible.

Step 2. Reposition the Yoke into the CRT for best raster centering.

Step 3. Readjust the Vertical Size Control, R208, to specified dimensions.

Step 4. Secure and bond the Yoke to the neck of the CRT using hot melt adhesive to prevent slippage.

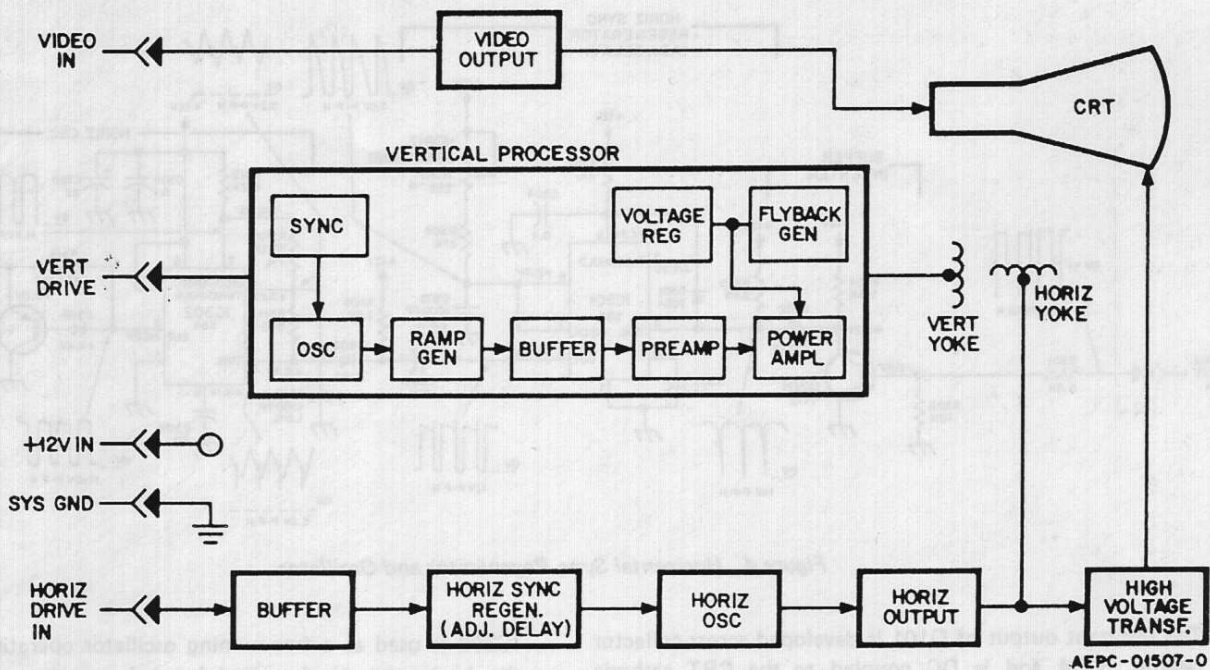

Figure 2. MD1000-190 Block Diagram

## THEORY OF OPERATION

### GENERAL

The Model MD1000-190 Series Monitors are direct drive units requiring separate video, horizontal drive and vertical drive inputs. All are TTL compatible. Power is supplied to the monitor from an external +12VDC source.

The monitor consists of a Video Amplifier, a Vertical Processing stage, and five stages of Horizontal Deflection.

### VIDEO AMPLIFIER (Refer to Figure 3)

The linear video amplifier consists of a one stage amplifier, Q101, capable of providing a minimum voltage gain of 10 with a 2.5V PP of signal input.

A TTL compatible non-composite video signal, is DC coupled to the base of Q101 via R103. Capacitor C102 and resistors R105, R106, maintain a flat frequency response whenever Q101 conducts.

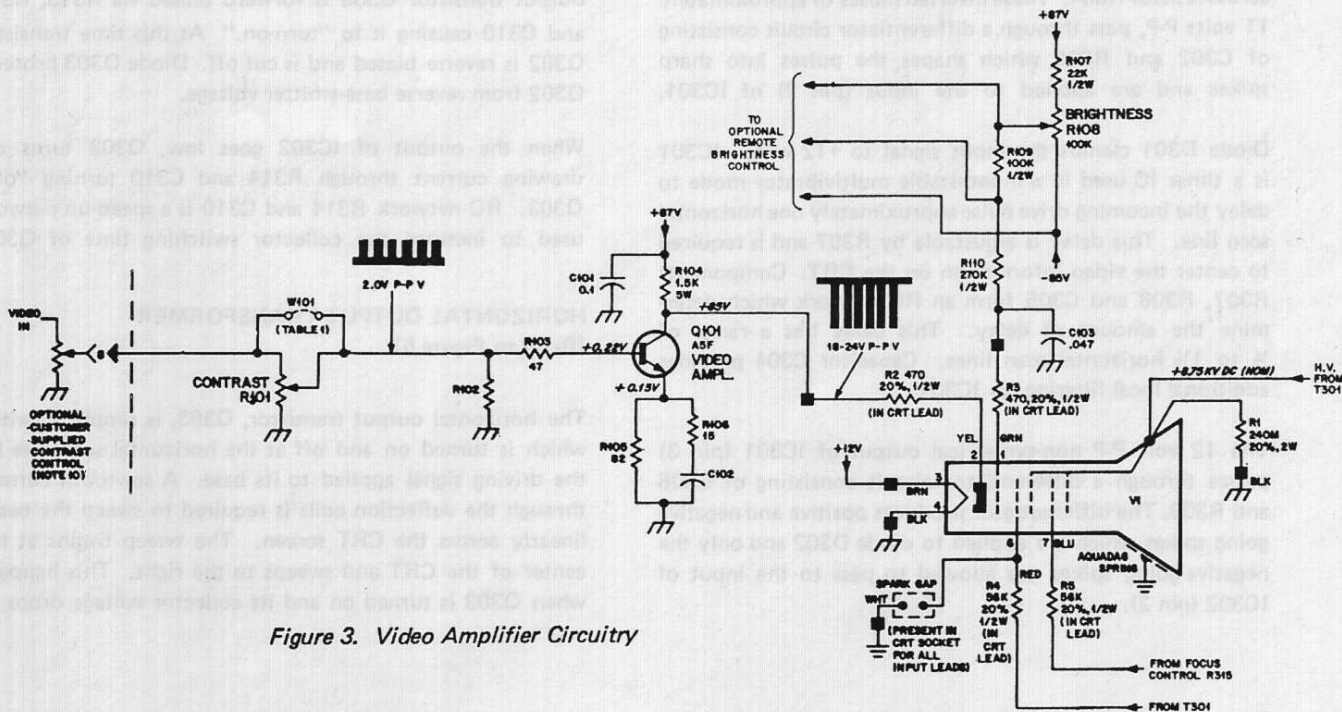

Figure 3. Video Amplifier Circuitry

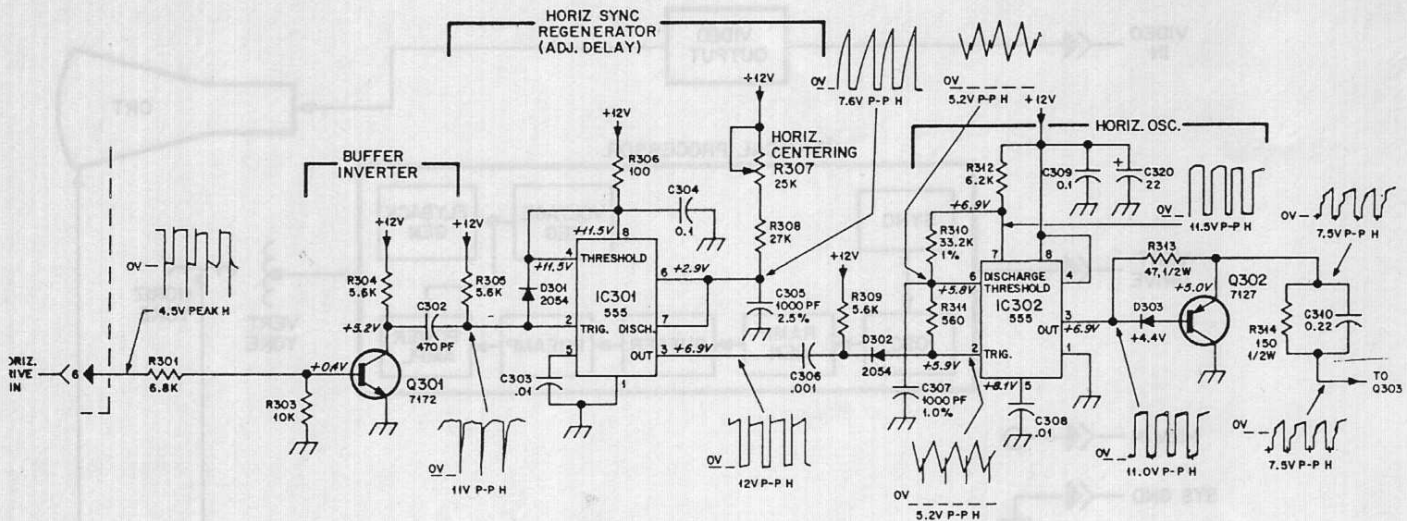

Figure 4. Horizontal Sync Regenerator and Oscillator

The resultant output of Q101 is developed across collector resistor R104 and is DC coupled to the CRT cathode via resistor R2. Q101 is protected from the CRT by a spark gap built into the CRT socket and R2 further isolates Q101 from transients.

#### HORIZONTAL AMPLIFIER AND OSCILLATOR (Refer to Figure 4)

Transistor Q301 is a single stage buffer/inverter which operates as a switch. During a no-signal condition, Q301 is biased at cut-off. The horizontal drive input is DC coupled to the base of Q301. Positive-going horizontal drive pulses of 2.5 volts P-P will turn Q301 on and cause it to saturate. The inverted output of Q301 is developed across resistor R304. These inverted pulses of approximately 11 volts P-P, pass through a differentiator circuit consisting of C302 and R305 which shapes the pulses into sharp spikes and are applied to the input (pin 2) of IC301.

Diode D301 clamps the input signal to +12 volts. IC301 is a timer IC used in a mono-stable multivibrator mode to delay the incoming drive pulse approximately one horizontal scan line. This delay is adjustable by R307 and is required to center the video information on the CRT. Components R307, R308 and C305 form an RC network which determine the amount of delay. This delay has a range of 1/2 to 1 1/2 horizontal scan lines. Capacitor C304 provides additional local filtering for IC301.

The 12 volt P-P non-symmetrical output of IC301 (pin 3) passes through a differentiator circuit consisting of C306 and R309. The differentiator produces positive and negative going spikes which are applied to diode D302 and only the negative-going spikes are allowed to pass to the input of IC302 (pin 2).

IC302 is used as a free-running oscillator operating above the horizontal synchronized input frequency. If a loss of a horizontal drive signal occurs, the oscillator will free-run at a higher frequency reducing the high voltage developed by the flyback transformer. This prevents any damage to components in the horizontal output circuitry. Components R310, R311, R312 and C307 determine the free-running frequency of the oscillator. The output of IC302 (pin 3) is an 11 volt P-P non-symmetrical square wave.

#### HORIZONTAL OUTPUT (Refer to Figure 5)

When the output of IC302 (pin 3) goes high, horizontal output transistor Q303 is forward biased via R313, R314 and C310 causing it to "turn-on." At this time transistor Q302 is reverse biased and is cut off. Diode D303 protects Q302 from reverse base-emitter voltage.

When the output of IC302 goes low, Q302 turns on; drawing current through R314 and C310 turning "off" Q303. RC network R314 and C310 is a speed-up network used to increase the collector switching time of Q303.

#### HORIZONTAL OUTPUT TRANSFORMER (Refer to Figure 5)

The horizontal output transformer, Q303, is simply a switch which is turned on and off at the horizontal scan rate by the driving signal applied to its base. A sawtooth current through the deflection coils is required to sweep the beam linearly across the CRT screen. The sweep begins at the center of the CRT and sweeps to the right. This happens when Q303 is turned on and its collector voltage drops to



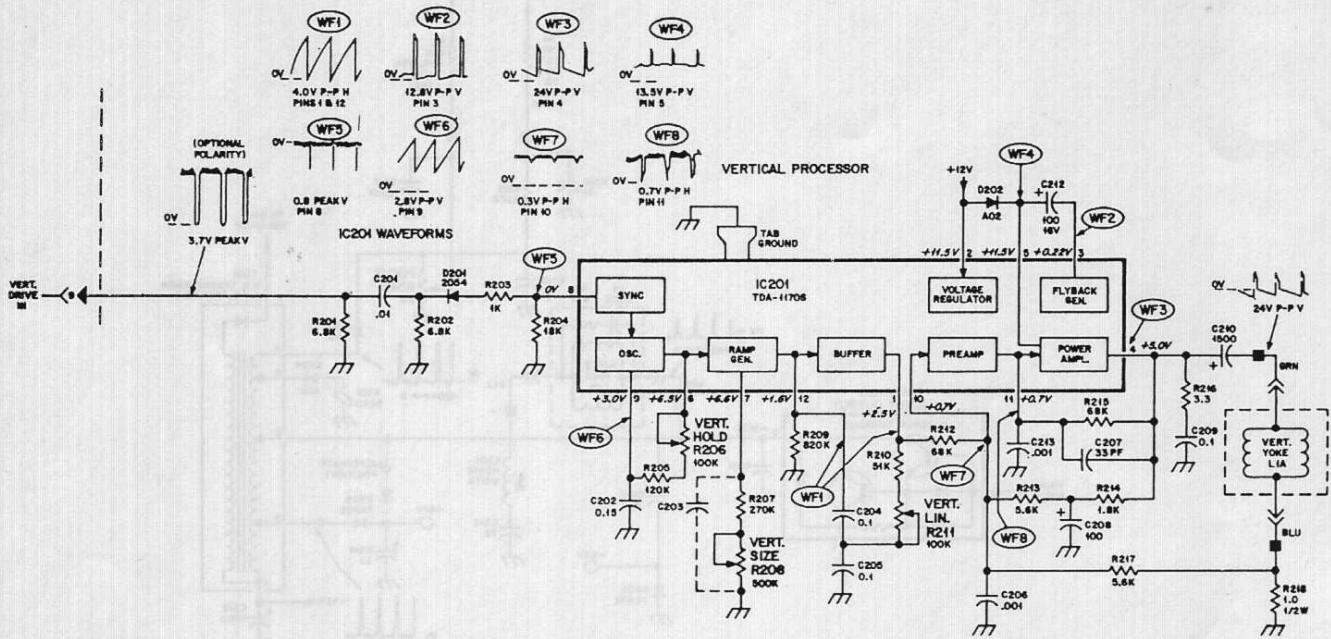

Figure 6. Vertical Deflection Circuitry

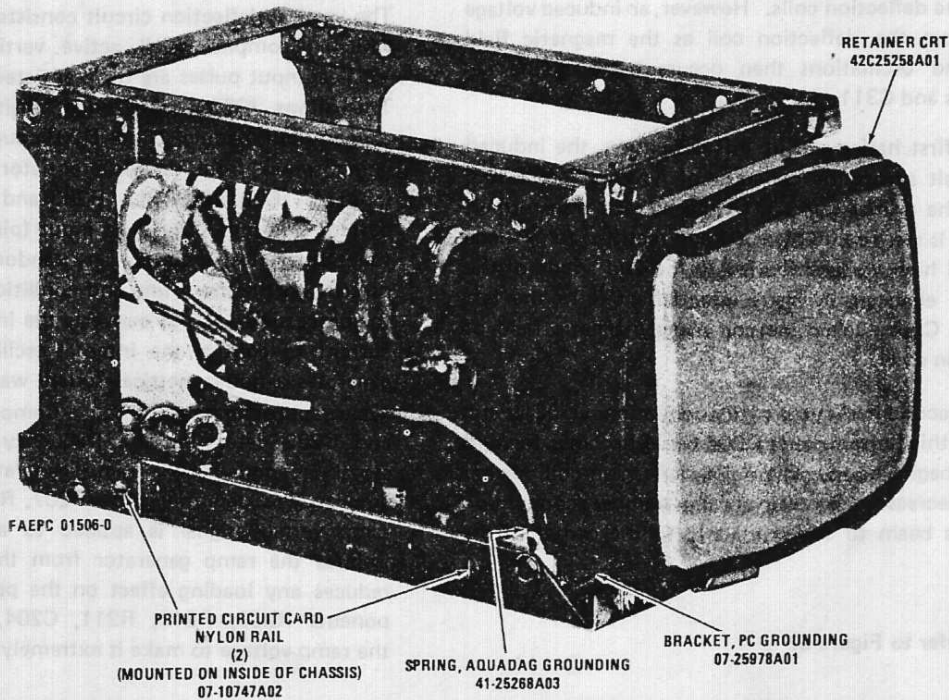

Figure 7. Model MD1000-190 Series (Side View)







## REPLACEMENT PARTS LIST

REF. NO.	PART NO.	DESCRIPTION	REF. NO.	PART NO.	DESCRIPTION
<b>CAPACITORS: (All Values are in Microfarads Unless Otherwise Noted.)</b>			<b>TRANSISTORS</b>		
C101	21R29964A05	0.5 +80-20 Z5U 100V Spcl.	Q101	48R137093	NPN TRANSISTOR A5F
C102	21S180E58	150PF 5% NPO 100V (MD1000-190)	Q301	48R137172	NPN TRANSISTOR 7172
	21-S180B53	470PF 10% Z5F 100V Disc. (MD1900-191)	Q302	48R137127	PNP TRANSISTOR 7127
C103	8R29959A65	0.047 10% 200V Plystr.	Q303	48-03025A00	DARL. TRANSISTOR 3025
C201	8R29959A41	0.01 10% 200V Plystr.		1V25576A60	includes heatwink and transistor 3025
C202	8R29967B92	0.15 10% 50V Plystr.	<b>RESISTORS/CONTROLS</b>		
C204,5	8R29967A11	0.1 10% 50V Plystr.	NOTE: Only power or special resistors are listed. Use the description when ordering standard values of fixed carbon resistors.		
C206	21S180B51	0.001 10% X5F 500V Disc.	R1	6R29978A01	RES. Fixed 240M
C207	21S180B94	33PF 10% NPO 500V Disc.	R101	18D25245A02	CONTROL, Contrast Var. 1K
C208	23R29914A40	100 16V PCM lytic	R108	18D25245A15	CONTROL, Brightness Var. 100K
C209	8R29959A76	0.1 10% 100V Plystr.	R206	18D25245A15	CONTROL, Var. Vert. Hold 100K
C210	23R29914A68	1500 25V PCM lytic	R208	18D25245A07	CONTROL, Var. Vert. Size 500K
C212	23R29914A40	100 16V PCM lytic	R211	18D25904A02	CONTROL, Var. Vert. Lin. 250K
C213	21S180B51	0.001 10V X5F 500V Disc	R307	18D25245A40	CONTROL, Var. Horiz. Centering 25K
C302	21S180B53	470PF 10% X5F 100V Disc	R315	18D25245A32	CONTROL, Var. Focus 2M
C303	21S180B90	0.01 20% Z5F 100V Disc	<b>COIL/CHOKES</b>		
C304	21R29964A05	0.1 +80-20 Z5U 100V Spcl.	L1 A/B	24D25290A03	COIL, deflection
C305	8R29970A03	0.001 2.5% 100V polyprop.	L301	24D25603A03	COIL, width
C306	21S180B51	0.001 10% X5F 500V Disc	<b>INTEGRATED CIRCUITS (IC)</b>		
C307	8R29970A02	0.001 1% 100V Polyprop.	IC201	51R06015A00	IC, TDA1170S Vert. Proc.
C308	21S180B90	0.01 20% Z5U 100V Disc.	IC301, 302	51R06332A00	IC, 555 Timer
C309	21R29964A05	0.1 +80-20% Z5U 100V Spcl.	<b>TRANSFORMERS</b>		
C310	8R29959A88	0.22 10% 100V Plystr.	T301	24D25291A21	TRANSF., horiz. output (MD1000-191)
C311	8R29956A38	0.039 5% 200V Mylar (MD1000-190)	T301	24D25291A25	TRANSF., horiz. output (MD1000-190)
	8R29956A46	0.068 5% 200V Mylar	<b>MISCELLANEOUS</b>		
C312	23R29910A05	22 25V Lytic	V1	9610769A01	CRT, 5-in P4/H
C313	8R29959A65	0.047 10% 200V Plystr.		0725978A01	BRACKET, PC grounding
C314	23R29914B49	22 100V PCM Lytic		4125268A03	SPRING, dag.
C315, 316	8R29959A42	0.01 10% 400V Plystr.		5925667A0X	NOTE: For Replacement of magnetic yokes, order replacement by specifying the Model No., description of the unit, and the unique CRT display characteristics.
C317	21S180C41	0.0027 20% Z5F 100V Disc.		1V25576A56	CRT socket and lugs
C318	23R29914A66	1500 25V Lytic		9D25241A11	SOCKET, CRT
C319	21R29964A05 (not used)	0.1 +80-20% Z5U 100V Spcl (MD1000-191)		42D25298A04	ANODE connector
C320	23R29914A77	22 35V Lytic	E301	76A25809A02	Ferrite Bead.
<b>DIODES/RECTIFIERS</b>					
D201	48-02054A00	DIODE, 2054			
D202	48-00191A02	DIODE, A02			
D301,302, 303	48-02054A00	DIODE, 2054			
D304	48-00191A05	DIODE, A05			
D305,306	48-02075B02	DIODE, 75B02			
D307	48R134978	DIODE, D1K			